

# ZETOR

**SYSTEM** *Trac - Lift* 



**Powerful**

NEW LINE OF FRONT END LOADERS

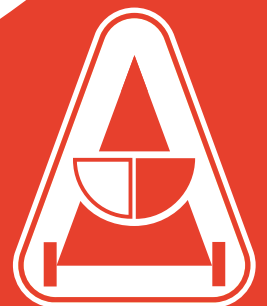

# NEW LINE POWERFUL MERITS

## New, modernized design

Improved construction of new line „Powerful“ is based on increasing demands of users on quality, reliability, price, design and comfortable using.

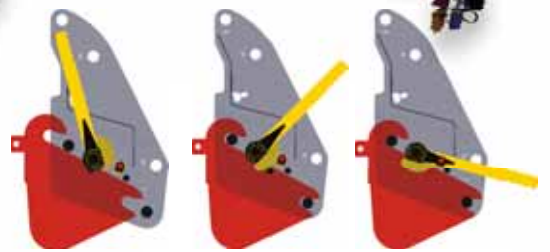
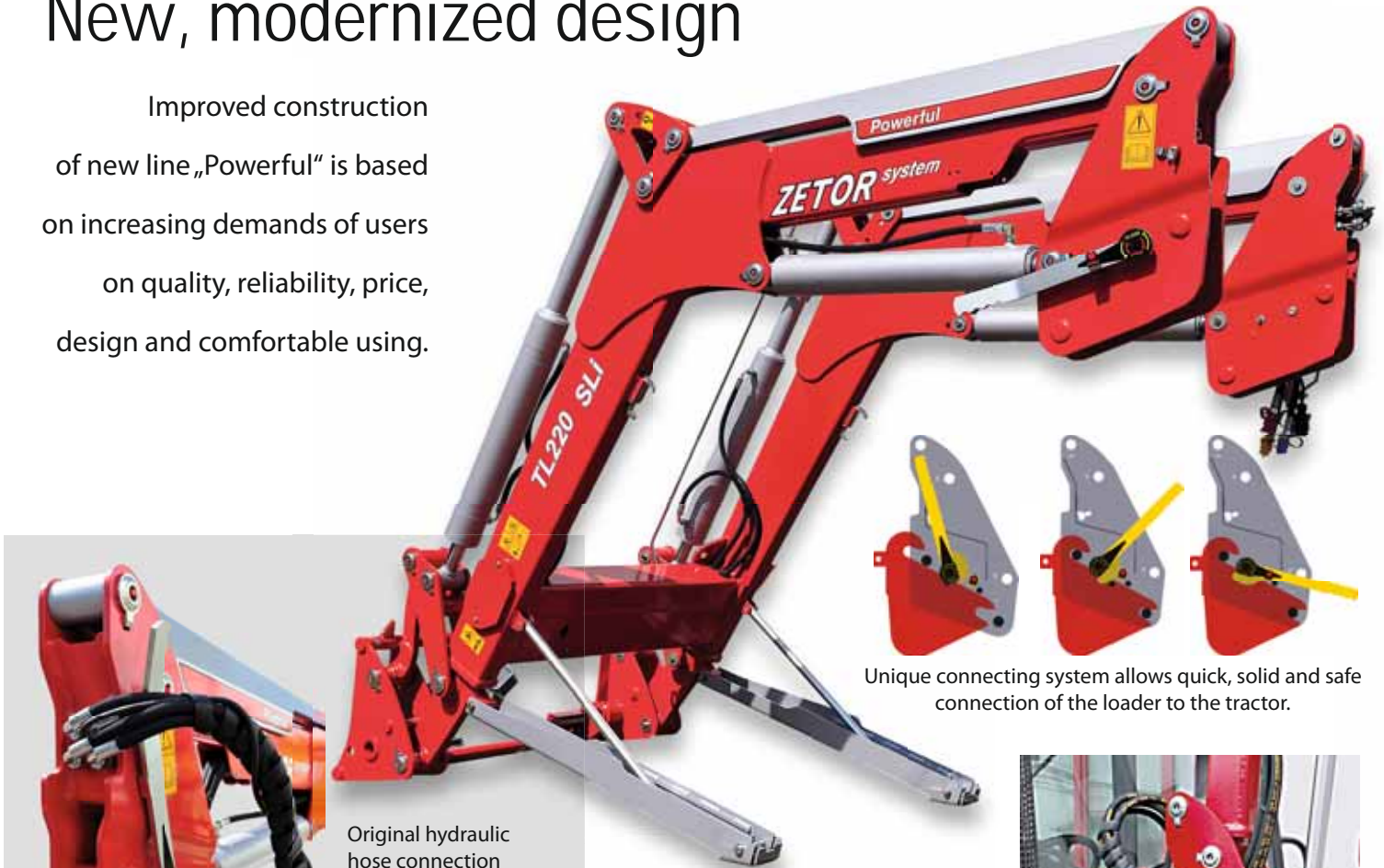

Unique connecting system allows quick, solid and safe connection of the loader to the tractor.



Original hydraulic hose connection system in loader connection clamps stops unwanted hose movement near exhaust and front window.

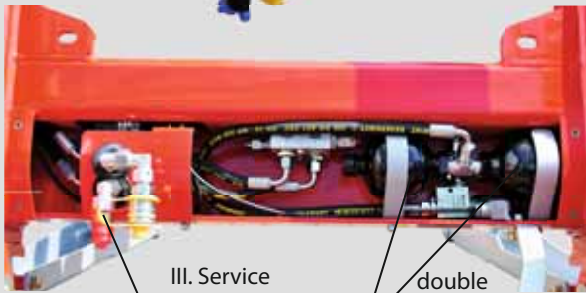

III. Service

double Accumulator



Accumulator

Multilock



New tractor bracket construction is mainly focused on stiffness and easy access to all service points of the tractor.



Protected hydraulic system is placed inside the loader arms and inside front bracing strut. The bracing strut also increases solidity of the loader.



New design of support feet improves comfort while using.

# ATTACHMENTS

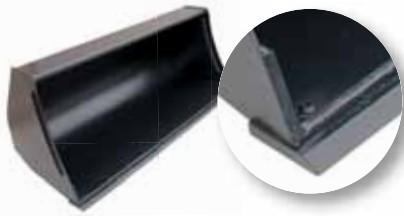

Standard bucket

	BD 135	BD 160	BD 185	BD 210
Width	1,35 m	1,60 m	1,85 m	2,10 m
Capacity	0,41 m <sup>3</sup>	0,48 m <sup>3</sup>	0,56 m <sup>3</sup>	0,63 m <sup>3</sup>
Weight	180 kg	200 kg	220 kg	240 kg



Bucket with teeth

	BDT 135	BDT 160	BDT 185	BDT 210
Width	1,35 m	1,60 m	1,85 m	2,10 m
Capacity	0,41 m <sup>3</sup>	0,48 m <sup>3</sup>	0,56 m <sup>3</sup>	0,63 m <sup>3</sup>
Weight	205 kg	235 kg	265 kg	295 kg

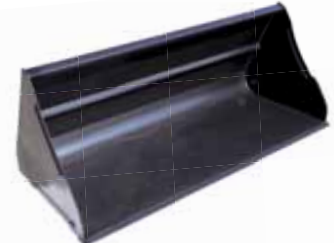

Big volume bucket

	BDL 175	BDL 195	BDL 215	BDL 240
Width	1,75 m	1,95 m	2,15 m	2,40 m
Capacity	0,81 m <sup>3</sup>	0,9 m <sup>3</sup>	1,12 m <sup>3</sup>	1,25 m <sup>3</sup>
Weight	250 kg	260 kg	325 kg	355 kg



Silage cutter

	SC 140
Width	1,4 m
Capacity	1,1 m <sup>3</sup>
Weight	440 kg



Multibucket

	BM 150	BM 170	BM 190
Width	1,5 m	1,7 m	1,9 m
Capacity	0,75 m <sup>3</sup>	0,85 m <sup>3</sup>	0,95 m <sup>3</sup>
Weight	280 kg	330 kg	380 kg



Grab fork

	FG 150	FG 170	FG 190
Width	1,5 m	1,7 m	1,9 m
Capacity	0,8 m <sup>3</sup>	0,9 m <sup>3</sup>	1,0 m <sup>3</sup>
Weight	235 kg	250 kg	270 kg



Protecting frame

Aggregation	FP 115 a FP 130
Weight	30 kg



Bale spike

Aggregation	FP 115 a FP 130
Weight	25 kg



Pallet fork

	FP 115	FP 130
Width	1,15 m	1,30 m
Lifting capacity	1250 kg	1250 kg
Weight	155 kg	160 kg



Pallet lock

	PL
Aggregation	FP 115 a FP 130
Weight	64 kg



Fork

	F 130	F 150	F 170	F 190	F 210
Width	1,3 m	1,5 m	1,7 m	1,9 m	2,1 m
The number of spikes	7	8	9	10	11
Weight	115 kg	135 kg	150 kg	165 kg	180 kg



Bale fork

	FB 110
Width	1,1 m
The number of spikes	3
Weight	125 kg



Stacking equipment

	ES 120
Width	1,2 m
The number of spikes	3
Weight	300 kg
Lift	1,6 m
Lifting capacity	600 kg



Hook for bigbag

Weight: 95 kg  
Lifting capacity: 1000 kg



Cross holder

Weight: 30 kg  
Lifting capacity: 1000 kg



Tongs for round bales

	TB 160
Width	1,3 m
Weight	210 kg



Balancing weight

Weight: 120 kg

High quality attachments with proven euro-hitch system can be used on current version same as on new Powerfull line.

# TECHNICAL SPECIFICATIONS

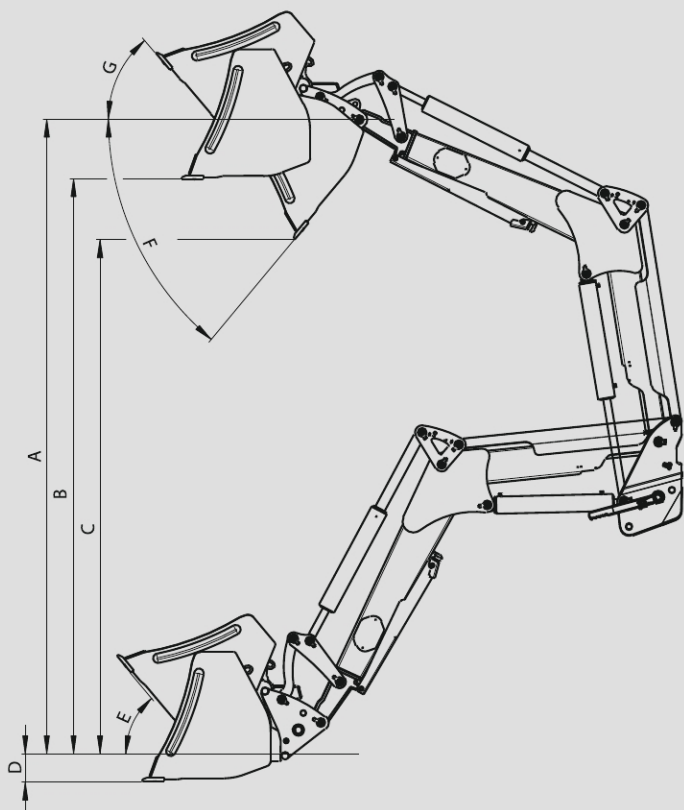

	120i/120SLi 50 - 80 HP	220SLi/260SLi 70 - 110 HP	220SLi/260SLi 70 - 110 HP	320SLi/360SLi 78 - 120 HP
Hydraulic cylinder	70 mm	70 mm	80 mm	80 mm
A - Lift height to pivot pin	3580	3880	3880	4180
B - Loading height	3260	3560	3560	3860
C - Filling height	2650	2950	2950	3250
D - Depth reach	200	250	250	250
E - Roll back angle at the bottom	45°	45°	45°	45°
F - Dump angle at the top	70°	65°	65°	60°
G - Rollback angle at the top	50°	55°	55°	55°
Lifting capacity down /at the pivot pin/	2100 kg	2000 kg	2650 kg	2200 kg
Lifting capacity up /at the pivot pin/	1650 kg	1400 kg	1850 kg	1600 kg
Lifting capacity on pallet fork down – 0,8 m from the pivot pin	2000 kg	1850 kg	2450 kg	2000 kg
Lifting capacity on pallet fork up – 0,8 m from the pivot pin	1500 kg	1250 kg	1700 kg	1400 kg

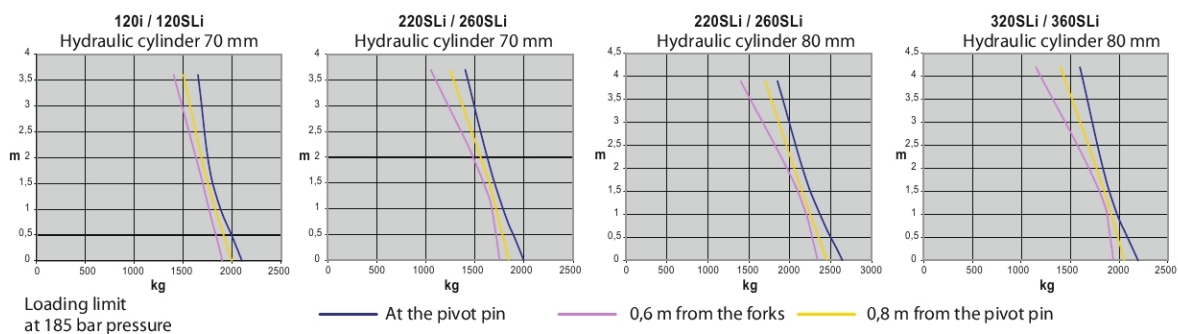

**Zetor Tractors Ireland Limited**  
**Clane Business Park**  
**Clane, Co. Kildare**  
**tel.: 045 902620**